



Industrial Freezer Sales

A division of IDS

5311 Derry Avenue Building D Agoura Hills CA 91301

Phone (818) 597-4300 Fax (818) 597-4301

www.freezerlink.com

HSCRI Test Cabinet with Humidity Component SCRI Test Cabinet WITHOUT Humidity - Test Only

Standard HSCRI and SCRI Test Chamber Features:

- Programmable logic microprocessor controller with LCD Control Panel with message center, 4 x 20 character LCD display.
- Humidity control.
- Continuous product temperature display.
- Air probe with air temperature Hi/Lo alarms audible & visual.
- Programmable ramp soak feature.
- 2 levels of user password protection (set points and parameters).
- 100 event alarm logging including Date/Time Stamp and product temperatures stored in nonvolatile Flash memory.
- Integrated Hi/Lo alarm tests.
- Door ajar alarm with adjustable delay time period.
- Power failure alarm.
- Remote alarm contacts.
- Stainless steel interior.
- Coated evaporator.
- Key lock door and casters.
- Interior drain with plug.
- Exterior finish of heavy gauge steel painted with white scratch resistant baked enamel.
- 3 epoxy coated wire shelves.
- Thermostatically controlled door frame heater.
- Industrial quality refrigeration system.
- Streamlined refrigeration design optimizes air flow and temperature uniformity
- Complete cabinet is foamed-in-place with CFC Free high density polyurethane foam insulation.
- **SCRI** Operating range temperature: 4° C to 70° C;
- **HSCRI** Operating range **with humidity control**: 5° C to 60° C.
- **Warranties**: 18 months parts and labor, 5 year compressor (US and Canada) 18 months parts (International).
- **UL, C-UL, CE Mark.**



*Standard HSCRI -1S24 Test Chamber Shown



Industrial Freezer Sales

A division of IDS

5311 Derry Avenue Building D Agoura Hills CA 91301

Phone (818) 597-4300 Fax (818) 597-4301

www.freezerlink.com

Test Chamber Options:

- Temperature chart recorder & chart paper 2 pen
- Electrical duplex outlet
- RS485 communication output
- Access port 2" with sleeve and cover
- Sensor access port 1" diameter
- Shelf with clips
- Stainless steel exterior
- 4-20 MA output (temperature only)
- Export crating

Performance Ratings

SCRI-1S24 Temperature Test Chamber:

Temperature Variation: $\pm 0.5^{\circ}\text{C}$ @ 4°C to 70°C . The published temperature variation is derived from the maximum deviation of the thermocouple located nearest the chamber geometric center during the entire test period. (i.e. 25.0°C min and 26.0°C max divided by two would be a variation of $\pm 0.5^{\circ}\text{C}$).

Temperature Uniformity: $\pm 1^{\circ}\text{C}$ @ 4°C to 70°C .. The published temperature uniformity is derived from the maximum deviation of 9 thermocouples are placed on 3 horizontal planes, each plane having the thermocouples evenly spaced diagonally across the shelf from the left and right inner wall, and the middle sensor placed in the approximate geometric center of the shelf.

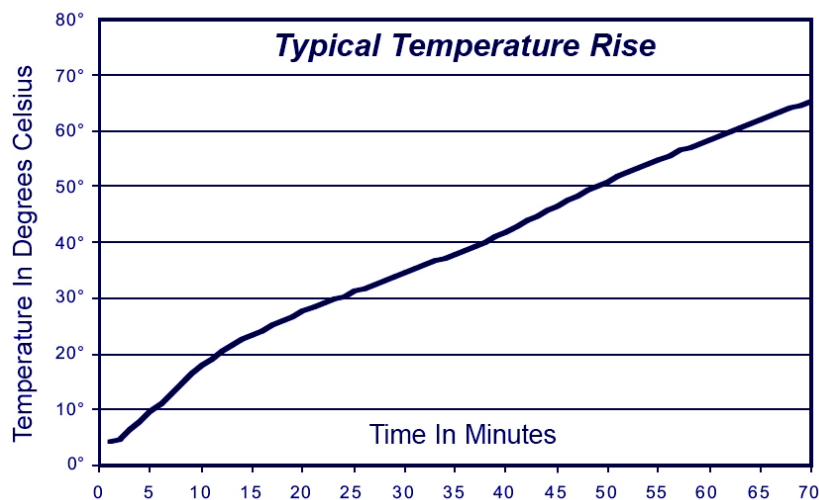



Industrial Freezer Sales

A division of IDS

5311 Derry Avenue Building D Agoura Hills CA 91301

Phone (818) 597-4300 Fax (818) 597-4301

www.freezerlink.com

Performance HSCRI-1S24 Humidity and Temperature Test Chamber

Humidity Variation: +5% @ 5°C to 60°C and RH within performance graph. Humidity variation is derived from the maximum deviation of the humidity sensor during the test period.

Performance data is based on 23°C, 50%RH ambient conditions, type T-24 Ga. thermocouples with 1.0oz. Brass slugs attached and no product in the chamber. Data may vary if; ambient conditions change, product load is added, or other changes cause interference to chamber airflow.

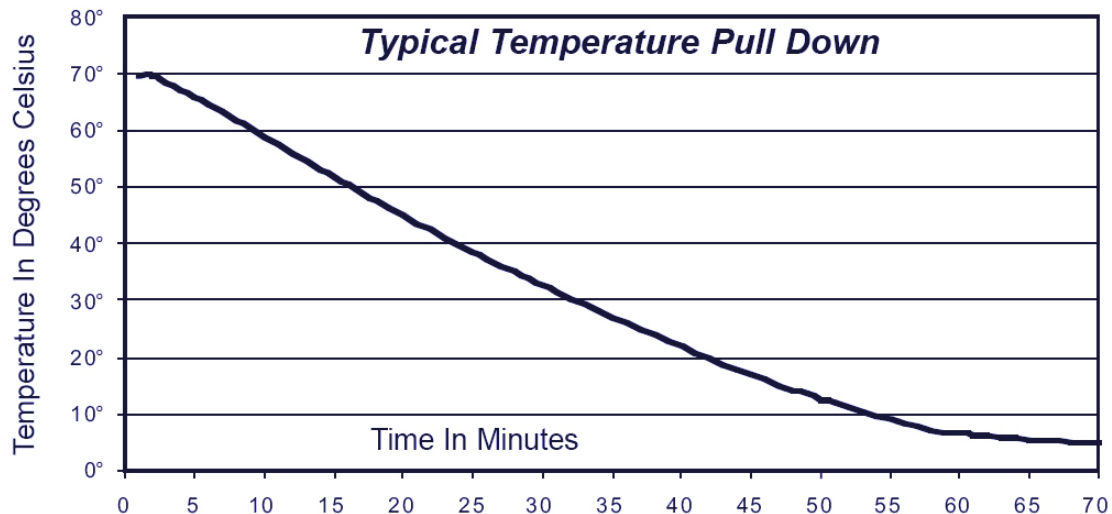

Humidification / Dehumidification: (HSCRI-1S24 continued)

Relative humidity is induced by a highly efficient centrifugal atomizer with a sealed motor and low maintenance reservoir. Dehumidification is achieved by the use of a separate dehumidification latent coil. Both systems are precisely controlled by the programmable logic microprocessor. The humidity controller utilizes a dry capacitance type sensor for rapid response to humidity changes with exceptional accuracy. The humidifier requires a water source with low mineral content; i.e., resistance of 0.5 - 1.0 megohm and a pressure of 10 – 100 psi. Reverse osmosis treated water is recommended. Water supply connection requires 1/4" plastic or copper tubing.



Industrial Freezer Sales

A division of IDS

5311 Derry Avenue Building D Agoura Hills CA 91301

Phone (818) 597-4300 Fax (818) 597-4301

www.freezerlink.com

Typical Temperature / Humidity Operation

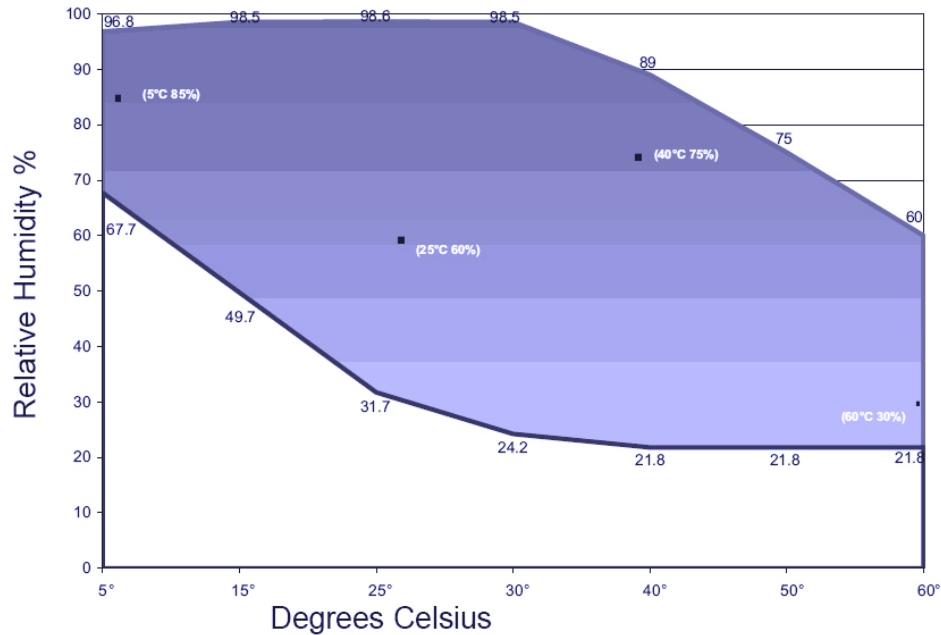

Humidified Units
Non-Humidified Units

HSCRI - 1S24
SCRI - 1S24

HSCRI - 2S52
SCRI - 2S52

HSCRI - 3S80
SCRI - 3S80

Dimensions

Crated Height (in) (cm)
Crated Width (in) (cm)
Crated Depth (in) (cm)
Crated Weight (lbs) (kg)

83" (211)
31-7/8" (81)
38-7/8" (98)
407 (184)

83" (211)
59" (150)
38-7/8" (98)
651 (295)

83" (211)
85-1/4" (216)
38-7/8" (98)
840 (381)

Interior Height (in) (cm)
Interior Width (in) (cm)
Interior Depth (in) (cm)

59" (149)
23-1/2" (59)
30" (76)

59" (149)
51" (129)
30" (76)

59" (149)
78-1/2" (199)
30" (76)

Overall Height (in) (cm)
Overall Width (in) (cm)
Overall Depth (in) (cm)

79-5/8" (202)
27-1/2" (69)
34-7/8" (88)

79-5/8" (202)
55" (139)
34-7/8" (88)

79-5/8" (202)
82-1/2" (88)
34-7/8" (88)

Gross Cubage (ft.3) (m3)
Shelf Area (sq. ft.) (m2)

24 (0.6)
12.8 (1)

52 (1)
28.5 (2)

80 (2)
42.8 (3)



Industrial Freezer Sales

A division of IDS

5311 Derry Avenue Building D Agoura Hills CA 91301

Phone (818) 597-4300 Fax (818) 597-4301

www.freezerlink.com

Standard Cabinet

Number of Shelves	3	6	9
Number of Casters	4	4	6
Condensing Unit Size	1/3 HP	1/2 HP	3/4 HP
Refrigerant	R-134a	R-134a	R-134a
Maximum Fuse Size AMPS	15	20	30
Total Amp Draw /8	11.7	13.4	18.79*
Total Amp Draw /5	11.3	N/A	N/A

Voltages & Power Description

NEMA Plug

NEMA Receptacle

230V, 1PH, 50HZ
 115/208-230V/1PH60HZ
 115/208-230V/1PH60HZ
 (3S80)

Module (IEC 60320)
 L-14-20P
 L-14-30P

Customer Supplied
 L-14-20R
 L-14-30R

Dimensions (All Humidified/Non-Humidified Test Units)

Single Door Units (HSCRI-1S24 and SCRI-1S24)

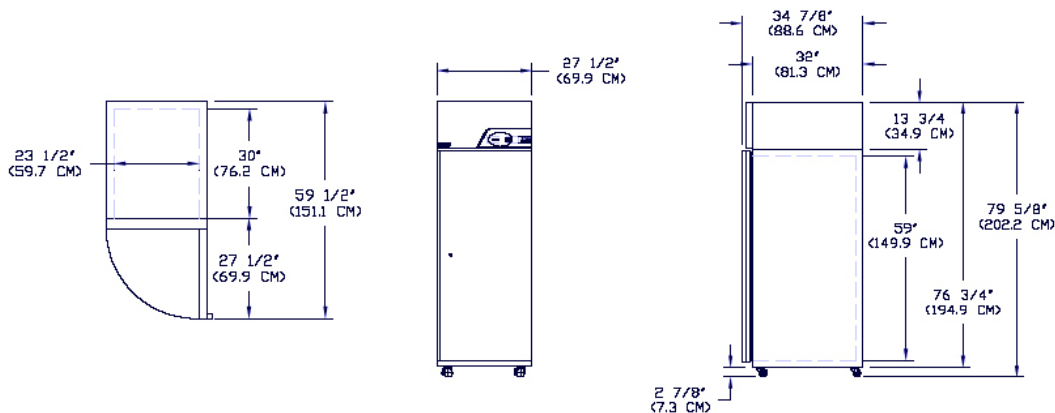



Industrial Freezer Sales
 A division of IDS
 5311 Derry Avenue Building D Agoura Hills CA 91301
 Phone (818) 597-4300 Fax (818) 597-4301
 www.freezerlink.com

Double Door Units (HSCRI-2S52 and SCRI-2S52)

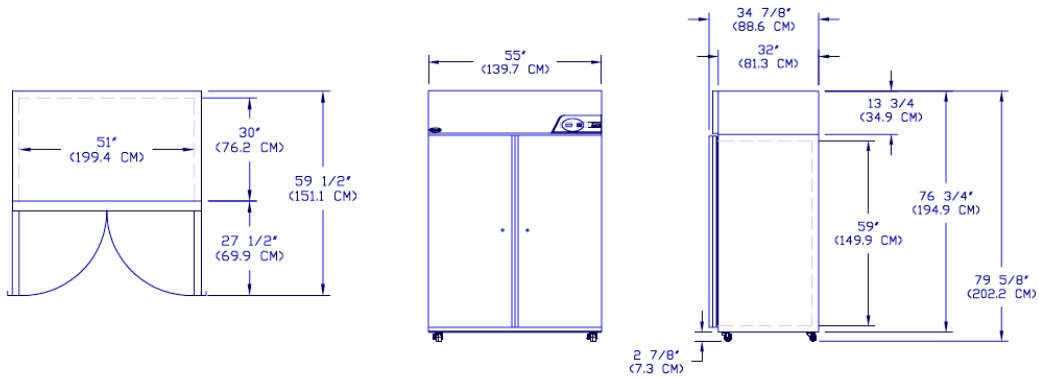

Triple Door Units (HSCRI-3S80 and SCRI-3S80)

