



Industrial Freezer Sales

A division of IDS

5311 Derry Avenue Building D Agoura Hills CA 91301

Phone (818) 597-4300 Fax (818) 597-4301

www.freezerlink.com

PF2S52-25 Upright -25°C Two Solid Door 52 Cu Ft

External Dimensions:

55"W x 34-7/8"D x 80-3/8"H

Internal Dimensions:

30"W x 51"D x 59"H

52 cubic feet: 2 Solid Doors

Voltage: 115V/1PH 60HZ

Plug Type: NEMA Plug Type 20P

Shipping weight: 590 lbs.

PF2S52-25 Upright -25°C

Two Solid Door 52 Cu Ft Features:

- Digital LED microprocessor with audible and visual Hi/Lo alarm
- Adjustable control range from -10°C to -25°C factory preset to -25°C
- Exterior front, sides, back and doors are white baked on enamel
- Exterior top and bottom are galvanized steel.
- Interior liner and interior door panel are painted white
- Cabinet is foamed-in-place with high density polyurethane foam insulation
- Heavy duty, pivot hinges and pull handles
- Magnetic door gaskets
- Key door lock(s)
- Four casters on one and two door models (2 locking) and six, casters (3 locking) on three door model
- 3 epoxy coated shelves per door section
- Complete perimeter anti-condensate door opening heater wires
- Interior light, switch activated
- Thermostatic expansion valve system



- Forced air flow refrigeration optimizes air flow and temperature uniformity
- Air-cooled condensing unit
- Automatic defrost
- Warranties: 18 months parts and labor. 5 year compressor (US and Canada) 18 months parts (International)
- UL and C-UL LISTED, Energy Star, CEC California Energy Commission

Optional Features

- Extra shelf with clips
- Legs in lieu of casters
- Stainless steel interior
- Stainless steel exterior
- Stainless steel drawer (maximum 8 per door)
- Wire basket drawer (maximum 6 per door)
- Sensor access port 1" diameter
- Temperature chart recorder with chart paper
- Export crating
- 4-20ma output
- Remote Alarm contacts, 4-20ma



Industrial Freezer Sales

A division of IDS

5311 Derry Avenue Building D Agoura Hills CA 91301

Phone (818) 597-4300 Fax (818) 597-4301

www.freezerlink.com

PF2S52-25 Upright -25°C Two Solid Door 52 Cu Ft Dimensions:

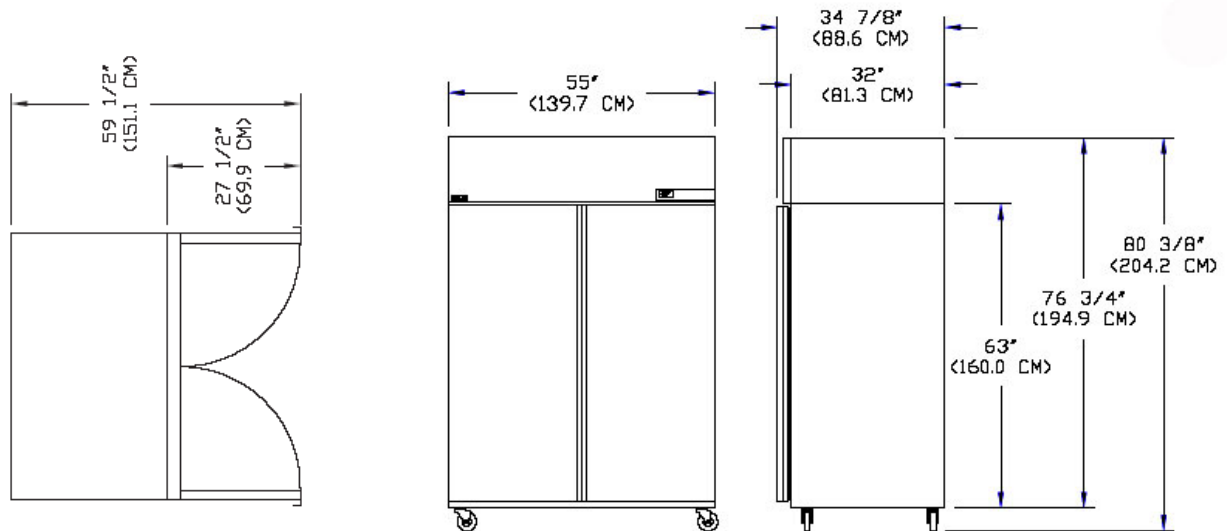

PF2S52-25 Upright -25°C Specifications:

Crated Height	83-3/4" (212.7 cm)
Crated Width	59" (149.9 cm)
Crated Depth	40" (101.6 cm)
Crated Weight	590lbs. (268.2 kg)
Interior Height	59" (149.9 cm)
Interior Width	51" (129.5 cm)
Interior Depth	30" (76.2 cm)
Overall Height	80-3/8" (204.2 cm)
Overall Width	55" (139.7 cm)
Overall Depth	34-7/8" (88.6 cm)
Gross Cubage (ft.3) (m3)	52.0 (1.47)
Shelf Area (sq. ft.) (m2)	28.6 (2.66)
Number of Shelves	6 (3 ea door standard, 8 max. each door)
Number of Casters	4 (2 locking)
Condensing Unit Size	3/4 HP
Refrigerant Type	R-404A
Maximum Fuse Size	20
Total Amp Draw 115V	12.4
Total Amp Draw 230V	8.96
Plug Type 115/230	NEMA 20P/Power Inlet (IEC 60320) Module