



## Industrial Freezer Sales

A division of IDS

5311 Derry Avenue Building D Agoura Hills CA 91301

Phone (818) 597-4300 Fax (818) 597-4301

[www.freezerlink.com](http://www.freezerlink.com)

### PF3S80-25 Upright -25°C Three Door 80 Cu Ft

#### External Dimensions:

82-1/2"W x 34-7/8"D x 80-3/4"H

#### Internal Dimensions:

78 1/2"W x 30"D x 59"H

**52 cubic feet:** 2 Solid Doors

**Voltage:** 115V/1PH 60HZ

**Plug Type:** NEMA 15P/R

**Shipping weight:** 590 lbs.



#### Upright -25°C Three Solid Door 80 Cu Ft Features:

- Digital LED microprocessor with audible and visual Hi/Lo alarm
- Adjustable control range from -10°C to -25°C factory preset to -25°C
- Exterior front, sides, back and doors are white baked on enamel
- Exterior top and bottom are galvanized steel.
- Interior liner and interior door panel are painted white
- Cabinet is foamed-in-place with high density polyurethane foam insulation
- Heavy duty, pivot hinges and pull handles
- Magnetic door gaskets
- Key door lock(s)
- Four casters on one and two door models (2 locking) and six, casters (3 locking) on three door model
- 3 epoxy coated shelves per door section
- Complete perimeter anti-condensate door opening heater wires
- Interior light, switch activated
- Thermostatic expansion valve system
- Forced air flow refrigeration optimizes air flow and temperature uniformity
- Air-cooled condensing unit
- Automatic defrost
- Warranties: 18 months parts and labor. 5 year compressor (US and Canada) 18 months parts (International)
- UL and C-UL LISTED, Energy Star, CEC California Energy Commission

#### Optional Features

- Extra shelf with clips
- Legs in lieu of casters
- Stainless steel interior
- Stainless steel exterior
- Stainless steel drawer (maximum 8 per door)
- Wire basket drawer (maximum 6 per door)
- Sensor access port 1" diameter
- Temperature chart recorder with chart paper
- Export crating
- 4-20ma output
- Remote Alarm contacts, 4-20ma



## Industrial Freezer Sales

A division of IDS

5311 Derry Avenue Building D Agoura Hills CA 91301

Phone (818) 597-4300 Fax (818) 597-4301

www.freezerlink.com

### PF3S80-25 Upright -25°C Three Door 80 Cu Ft Dimensions:

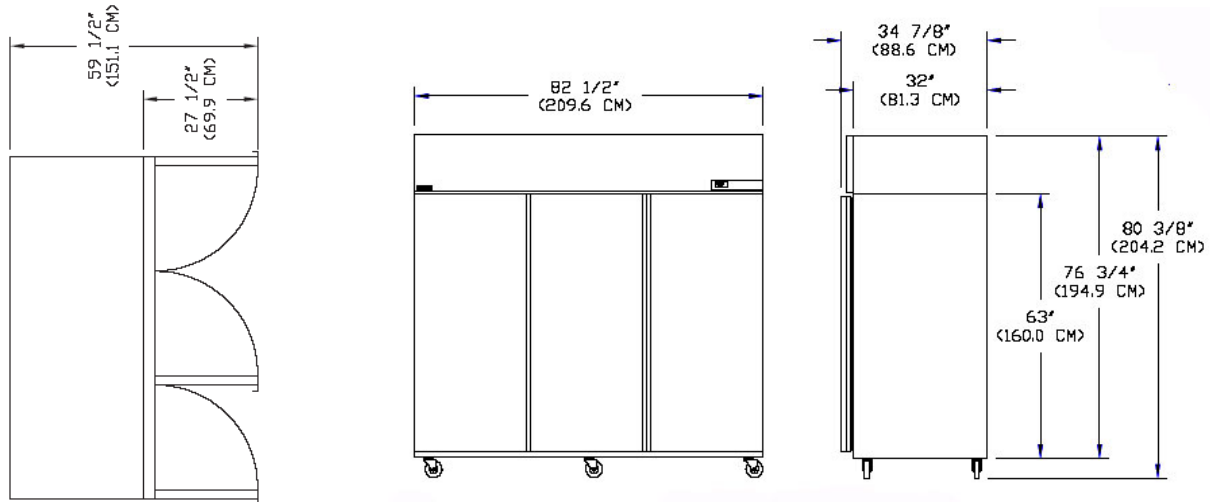

### PF3S80-25 Upright -25°C Specifications:

<b>Crated Height</b>	83-3/4" (212.7 cm)
<b>Crated Width</b>	86" (218.4 cm)
<b>Crated Depth</b>	38" (96.5 cm)
<b>Crated Weight</b>	805 (365.1 kg)
<b>Interior Height</b>	59" (149.9 cm)
<b>Interior Width</b>	78-1/2" (199.4 cm)
<b>Interior Depth</b>	30" (76.2 cm)
<b>Overall Height</b>	80-3/4" (204.2 cm)
<b>Overall Width</b>	82-1/2" (209.6 cm)
<b>Overall Depth</b>	34-7/8" (88.6 cm)
<b>Gross Cubage (ft.3) (m3)</b>	80.0 (2.26)
<b>Shelf Area (sq. ft.) (m2)</b>	42.84 (3.98)
<b>Number of Shelves</b>	9 (Standard, max 3 per door)
<b>Number of Casters</b>	6 (3 Locking)
<b>Condensing Unit Size</b>	1 HP
<b>Refrigerant Type</b>	R-404A
<b>Maximum Fuse Size</b>	15
<b>Total Amp Draw 115V</b>	7.8
<b>Total Amp Draw 230V</b>	6.49
<b>Plug Type 115/230</b>	NEMA 15P/R / Customer Supplied